

MODEL 49

Two outlets extruded aluminium gas taps with safety device

Construction

Body: Extruded aluminium alloy
Cone: Aluminium alloy
Cap: Die cast aluminium alloy
Spindle: Aluminium

Connections

Standard Inlet: Round 16mm. diameter
Standard Outlet: M12x1 female
Spindle dimension: 6x4,6mm.
Shape according to customer's request

Functional data

Maximum working temperature: 130°C (CE) or 150°C (CSA)
Maximum working pressure: 65 mbar
Flow: 45-45X = 270 l/h 45Y=260 l/h
Internal leak tightness: < 20 cc/h (at 150 mbar)
Stroke: 4,5mm

Overall dimensions

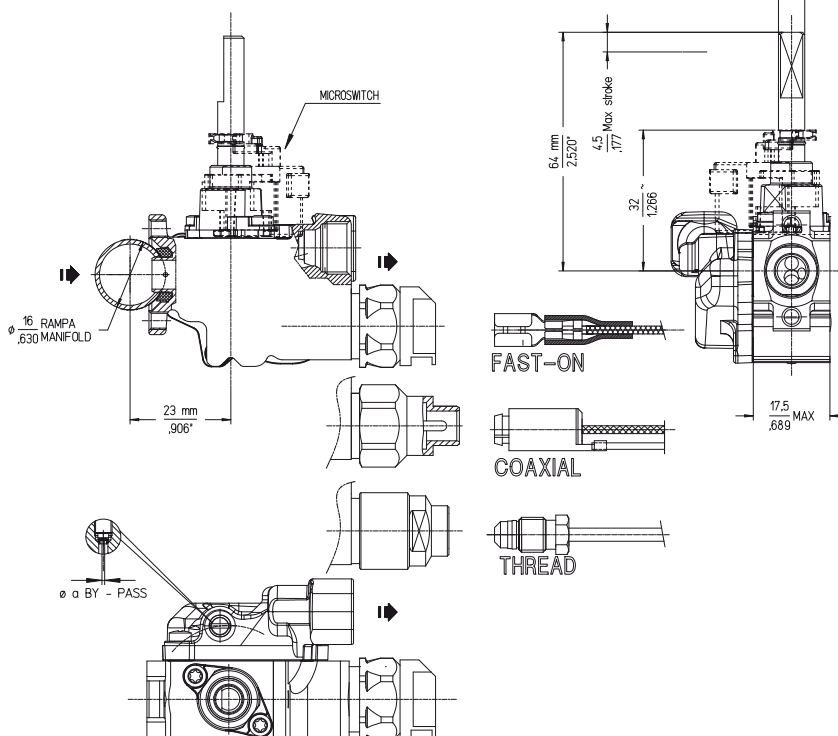

Installation

Maximum inlet torque: 1,5 Nm.
Maximum outlet torque: 15 Nm.
Maximum M8x1 thermocouple torque: 4 Nm.

Spindle rotation diagram

